

CARBON MONOXIDE TRANSDUCER

Analog output CO transducer for use with Macurco SS103-3A, SS103-10A & DVP-120 control panels and Building Automation Systems

CM-4

Internal combustion engines (cars, forklifts, etc.) produce carbon monoxide (CO), an odorless, colorless and deadly gas. Operators of enclosed parking garages, warehouses, maintenance facilities, etc., can protect people by either ventilating, continuously or installing automatic fan control systems like the **Macurco SS103 & DVP-120 Systems**. Automatic fan control systems in parking garages normally have a short payback, because fans operate 1 to 2 hours a day rather than 24 hours a day. The **CM-4** is powered from Macurco or other controllers, and provides a linear output to the controller. The **CM-4** conforms to the specifications of most building codes, ASHRAE standards, and occupational health regulations. Typical codes require that CO exposure be 1: 35 ppm or less on the TWA (Time Weighted Average) basis over 8 hours, and 2: 200 ppm or less on the STEL (Short Term Exposure Limit) basis over a one hour period. **Typical coverage is 5000 sq. ft. (464.5 sq. meters) per unit.** The **CM-4** uses a long life solid-state sensor (7 – 10 year), which does not require regular re-calibration. The **CM-4** replaces the SS102HC-1.

- Carbon Monoxide Transducer for use with the Macurco SS103-3A, SS103-10A (DC Voltage) or DVP-120 (4-20 mA) control panels, Building Automation Systems and any controller that accepts analog input.
- Microcomputer controlled operation.
- Dual output (4-20 mA Constant Current Loop or DC Voltage), internal switch.
- Re-calibration in the field with optional kit.
- Every unit factory calibrated.
- Operational status LED light

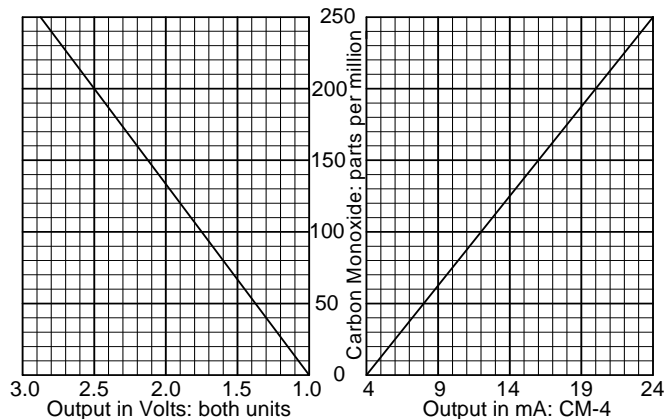

CM-4 SPECIFICATIONS

CO Range: 0-250 ppm
 Output Range: 1.00-2.88 VDC or 4-24 mA for 0-250 ppm of CO
 Output Type: DC Voltage or 4-20 mA Constant Current Loop
 Required Power Supply: 12-24 VDC or 12-24 VAC
 Power Consumption: 2.2 W @ 24 VDC
 Operating Temperature Range: 0-125 F
 Size: 4.5 X 4.5 X 2.1 inches
 Weight: 1 pound
 Color: gray

AUTHORIZED DISTRIBUTOR:
GasDetectorsUSA.com
Houston, Texas USA
sales@GasDetectorsUSA.com
832-615-3588

THE CM-4 IS SPECIFICALLY DESIGNED TO BE USED WITH MACURCO CONTROLLERS.
 SEE THE CM-4 OPERATING INSTRUCTIONS FOR CONNECTIONS TO THOSE CONTROL PANELS.

CONNECTING THE CM-4 WHEN NOT USING MACURCO PANELS.

NORMAL CM-4 HOOKUP

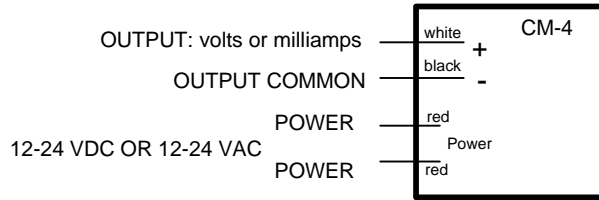

MULTIPLE CM-4 SYSTEM
 VOLTAGE OUTPUT

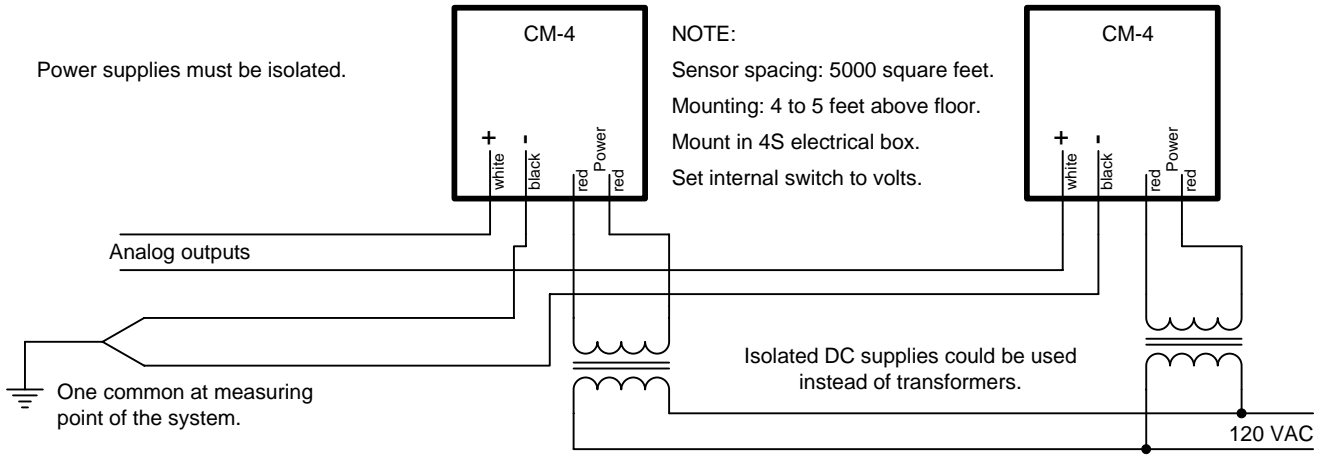

MULTIPLE CM-4 SYSTEM
 4 to 20 mA OUTPUT

